



Stem-N

Neck Preserving Primary Hip
Reconstruction Cementless

■ Table of Contents

	Introduction	2
1	Preparation	
	Indications & Contraindications	4
	Risk Factors	5
	Preoperative Planning	6
	Choice of Stem Size and Stem Type	7
	Positioning of Patient and Surgical Approach	7
2	Surgical Technique	8
	Determination of the Resection Level	9
	Preparation of the Proximal Femur	9
	Trial Reduction	10
	Inserting the Final Stem	12
	Final Trial Reduction	12
	Final Head Implantation	13
3	Ordering Information	14
	Implants Item Codes	15
	Instruments Item Codes	20

■ Important Note

Lincotek Bologna S.r.l., does not practice medicine. This surgical technique / brochure has been developed in consultation with an experienced team of surgeons to provide their peers with general guidance when implanting the Predicate Acetabular System. Proper surgical procedures and techniques are necessarily the responsibility of the medical professional. Each surgeon must evaluate the appropriateness of the surgical technique used based on personal medical training, experience and clinical evaluation of each patient individually.

■ Indications

Indications according to IFU:

- Extensive primary and secondary destruction of the joint to the extent that the functional efficiency of the locomotive apparatus is reduced;
- Severe pathological condition affecting the articulation caused by degenerative and rheumatoid arthritis;
- Joint fracture or bone necrosis;
- Post-surgical conditions after previous operations with or without consequent use of a prosthesis.

■ Contraindications

- On-going inflammatory process in the peri-articular region;
- Severe loss of bone tissue such as to inhibit a primary stabilisation of the prosthesis;
- Degenerative changes in the patient's neurological condition;
- Severe instability in the ligament area that cannot be remedied;
- Foreseeable causes of fatigue of the implanted joint due to obesity or excessive physical activity;
- Severe osteoporosis;
- Bone cancer in the implant anchoring area;
- Alcohol and drug abuse;
- Allergy to the materials employed;
- Lack of collaboration by the patient.

Relative contraindications:

- Adiposity
- Lacking or foreseeable not assured compliance
- Foreseeable overload/overstressing of the joint prosthesis
- Osteoporosis

■ Risk Factors

Complications:

- Hematomas in the region of the operation;
- Late onset of acute infections in the region of the operation;
- Momentary or persistent functional alterations in the nerves of the anatomical area concerned;
- Venous thrombosis, pulmonary embolism, heart failure;
- Change in position and/or loosening of the prosthesis;
- Joint dislocation;
- Shortening or lengthening of the limb concerned;
- Pathological bone fracture caused by changes in load;
- Allergic reactions or metallosis in the peripheral region of the implant;
- Periarticular ossification.



■ Preoperative Planning

The device should be implanted only by surgeons familiar with the joint replacement procedures described in the specific surgical techniques.

Preoperative planning provides useful information for the correct placement of the implant but does not necessarily indicate the appropriate sizing. The correct stem and cup size must be determined during surgery.

To achieve the best results preoperative planning using special templates (with specific magnification always advisable). It's suggested to do AP radiograph with adequate contrast.

The templates show both the profile of the cup and the center of rotation of the femoral head and the A-P main dimensions of the stem and the relative center of rotation according to the different head sizing.

In order to achieve successful hip replacement surgery, it is crucial to plan the procedure preoperatively, taking into consideration the patient's individual anatomy and level of physical activity.

The surgeon should conduct a thorough evaluation of the patient's clinical condition to determine the correct implant type and size, as well as its final intraosseous position.

To ensure optimal results, surgery should be planned in advance using appropriate templates, which must be compatible with the magnification factor of the X-rays.

Special X-ray templates are available in a standard 1.1:1 scale or in 1.15:1 scale.

The implant size should be selected from adequate AP and ML X-rays, ensuring legibility and large enough to accommodate the whole template. A second X-ray of the unaffected joint can be helpful.

Improper preoperative planning can result in the selection of incorrect implant types or incorrect positioning of implants.

It is desirable to have a load-bearing, stable acetabular fossa with solid lateral osseous coverage for acetabular surgeries and to evaluate properly the femoral bone conditions to select the adequate stem type.

The inclination of the cup should not be significantly above or below 45°, and anteversion should not be significantly above or below 15°.

Deviating from these boundaries may lead to a reduced range of motion, potentially resulting in subluxation or dislocation of the joint.

The combined stem/cup anteversion should be around 30° to improve the range of motion and reduce the dislocation risk and any potential impingement risks.

During hip replacement surgery, various surgical approaches can be utilized to implant the components.

The following steps are applicable for both postero-lateral and other surgical access routes.

The patient is placed in a lateral position for the procedure. The incision is made postero-laterally, followed by opening of the fascia-lata. The external rotator muscles are then resected, and the joint capsule is incised.

The femoral head is dislocated dorsally to allow for easy access and removal of the head from the socket. This is achieved by flexing the hip and abducting the leg, which allows the femoral head to dislocate freely. These steps are critical for a successful hip replacement surgery, regardless of the surgical approach utilized.

Before acetabular reaming, it is essential to have a clear and direct view of the acetabular site, regardless of the surgical approach selected, and before femurs broaching a good visibility must be achieved and the relative position of the great trochanter and the calcar should be properly evaluated. This requires the removal of any soft tissues and osteophytes that could obstruct visibility, allowing for a complete view of the entire acetabular socket and neck-femur region.

This is crucial to identify the presence of any cavitary or segmental defects and ensure accurate diagnosis and treatment.

Specific acetabular and femoral retractors are needed to facilitate acetabular exposure.

■ Choice of Stem Size and Stem Type

The stem size is selected in a way that, in frontal plane, the outline fills as much of the proximal femoral metaphysis as possible. In the sagittal plane, it must be ensured that the stem is suited to the anterior bow of the femur.

The stem is fixed proximally and therefore does not need to fit closely in the distal area. The size of prosthesis should be chosen so that the centre of rotation is correctly situated in the middle of the head respectively at a level with greater trochanter. Anteversion must be checked in the sagittal plane.

The stem size and the level for resection of the femoral neck should be selected such that the tip of the greater trochanter is level with the centre of the head of the prosthesis.

Lateralizing stems are available to achieve an anatomical reconstruction, even in case a high offset is required.

Preoperative planning gives an initial estimate but cannot conclusively determine the size of stem to be used. This is decided intraoperatively.

■ Positioning of Patient and Surgical Approach

All surgical approaches can be used while implanting Stems. All the following steps apply for postero-lateral surgical approach and all other surgical access routes.

The patient lies on his/her side. The incision is done postero-laterally.

After opening of the "fascialata", external rotator muscles are resected and the joint capsule is incised.

Then, the femoral head is dislocated in dorsal direction so that it lies free.



Surgical Technique

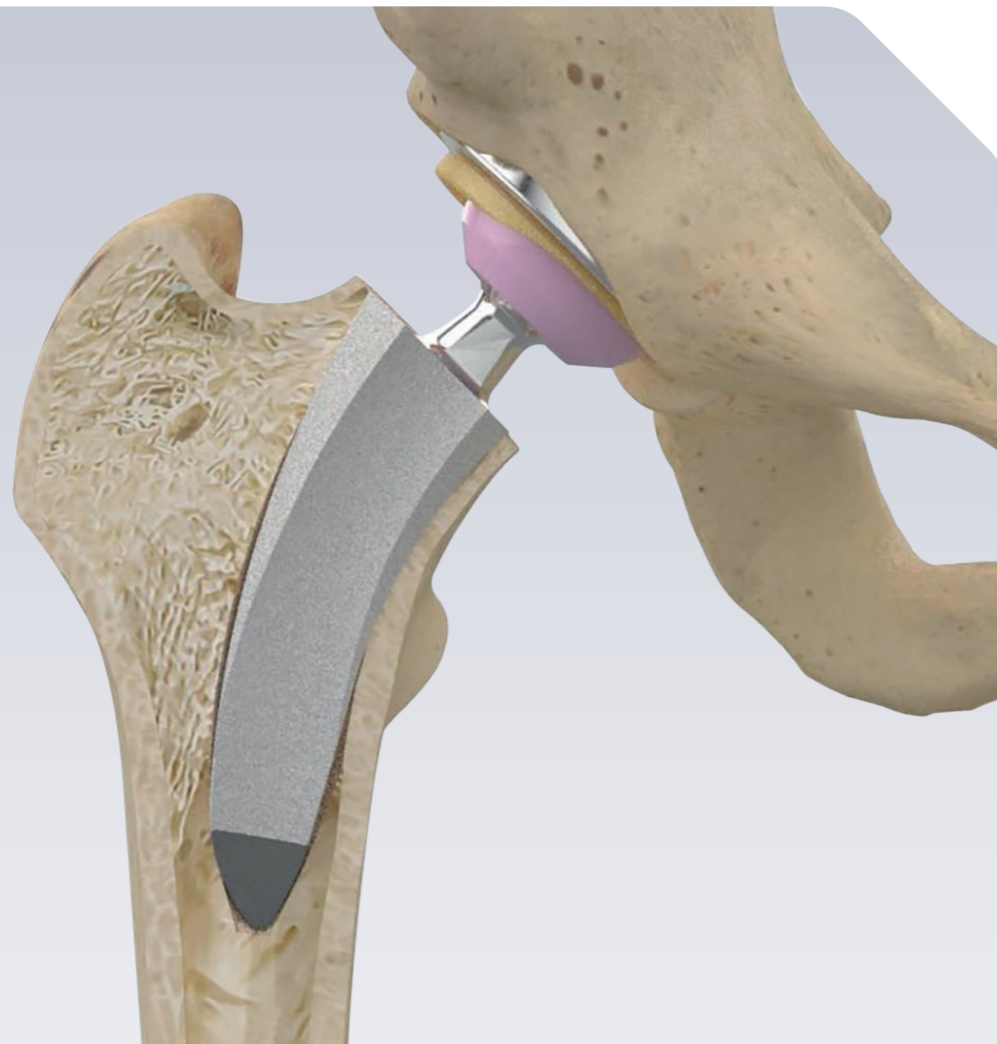

Determination of the Resection Level

The resection level has been defined in the pre-op planning. Resection should be sparing so that more bone can be resected later on if necessary. The angle of resection is perpendicular to the femoral neck axis [►Fig.1].

Then the resection is carried out at the planned level and should spare as much native neck as possible.



Preparation of the Proximal Femur

The medullary canal is opened with the smaller canal opener broach [►Fig.2]. This is done as laterally as possible to prevent varus positioning of the femoral component. The following bone broach is then used to compress the cancellous bone. This is an important step in the anchoring of the stem. Secure anchorage depends on a layer of compacted cancellous bone encompassing the implant.

After having opened the canal use the canal finder [►Fig.3] to verify that the femoral canal is properly open and then proceed with the broaches to identify the proper size. To fix the bone broach in the handle open the lever and insert the bone broach [►Fig.4] with the medial side in the direction of the lever [►Fig.4 b].

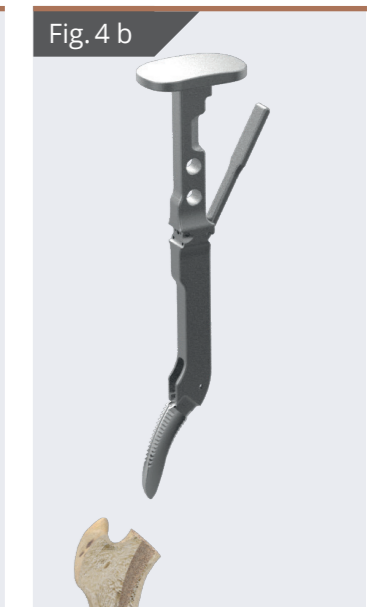

Close the lever. Start with the smallest bone broach [▶Fig.5]. Take into account the anteversion of the stem required (usually 15°).

Lateral compressive stress (which may lead to thigh pain later on) in the distal femur is avoided by inserting the bone broach in an axial direction.

Drive in the bone broach until the junction surface of the broach is flush with the resected neck surface [▶Fig.6].

Continue with progressively larger broach sizes until the bone broach is optimally seated in the femur (rotational stability, axial stability, implant level (height of center of rotation)).

In [▶Fig.6 b] see the neck cross section while inserting the broach.

When the optimal broach size is reached (which is not necessarily the same as planned preoperatively) remove the handle and leave the broach in place.



■ Trial Reduction

The acetabular cup is usually implanted before the stem. Trial reduction can then be carried out.

The inserted bone broach serves as a trial prosthesis on which the trial neck is inserted.

Select the appropriate trial neck segment according to the pre-op planning (stem types standard and lateralizing). The trial head is then placed on the trial neck [▶Fig.7].



The stability and range of motion of the joint are examined with the help of the trial components [▶Fig.8].

Finally, the trial head and neck segment are removed by hand [▶Fig.9] and the bone broach is removed with the help of the handle [▶Fig.10].

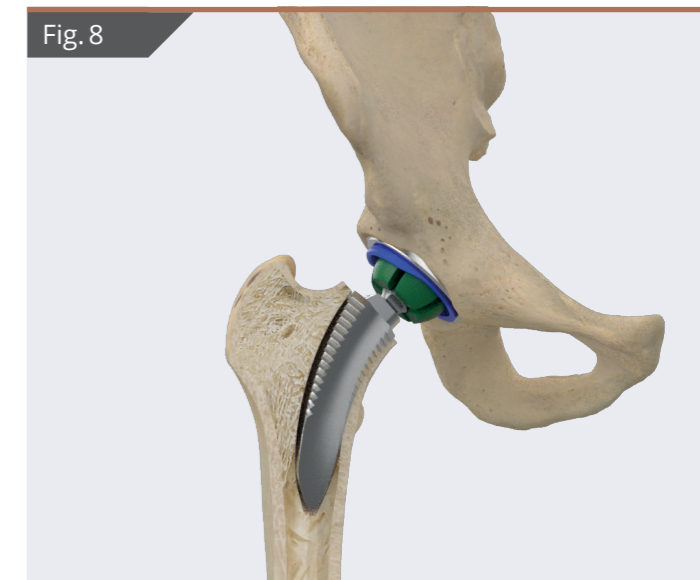

■ Inserting the Final Stem

Select the appropriate stem of the same size as the final bone broach and remove it from the sterile packaging. Position it into the femoral canal with the appropriate handle [▶ Fig.11].

Position the half-moon impactor [▶ Fig.12]. Drive in the stem with careful and controlled hammer blows until the transition line between the coating and the polished neck area corresponds to the profile of the last bone broach used.



■ Final Trial Reduction

At this point the correct head-neck-length can be checked again with the trial heads and trial liners [▶ Fig.13].

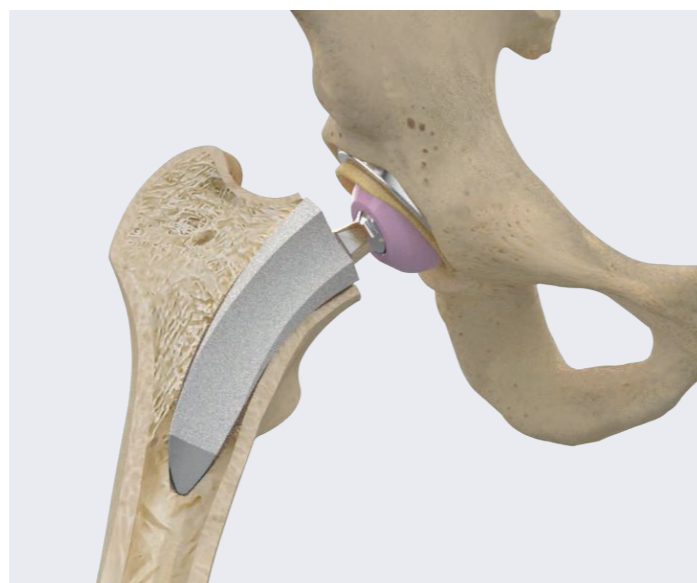

■ Final Head Implantation

Remove the appropriate prosthesis head (diameter, length, material) from the sterile packaging.

Clean and dry the taper of the stem thoroughly. This is particularly important with ceramic heads. Mount the head by hand using axial pressure and a turning motion.

Impact the head lightly if necessary, using the impactor for prosthesis heads [▶ Fig.14].

Reduction and suture:
Clean the joint surfaces thoroughly and then finally reduce the joint and test the final configuration and stability [▶ Fig.15] [▶ Fig.16].

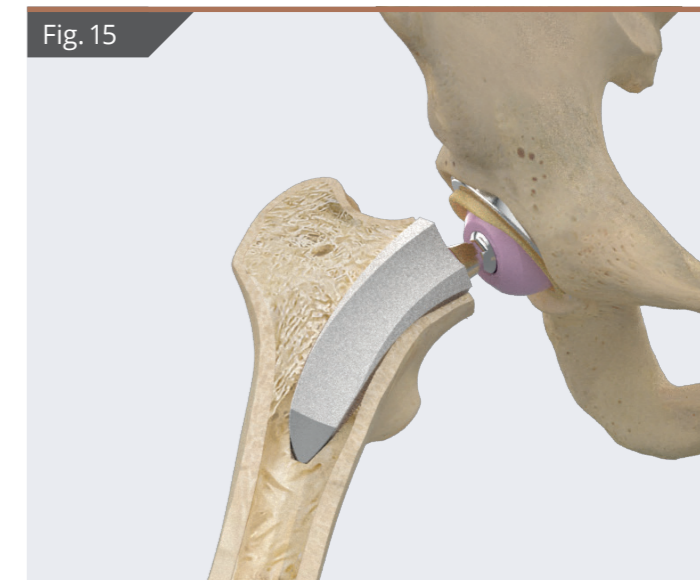

Ordering Information

Implants and Instruments



■ Stem-N: Cementless



Item Code	Description	Coating	Type	Main Material
XM01.1255.000.00	Stem-N Std 1 Ti-V + CaP	Ti-V + CaP	STD	Ti6Al4V - ISO 5832/3
XM01.1256.000.00	Stem-N Std 2 Ti-V + CaP	Ti-V + CaP	STD	Ti6Al4V - ISO 5832/3
XM01.1257.000.00	Stem-N Std 3 Ti-V + CaP	Ti-V + CaP	STD	Ti6Al4V - ISO 5832/3
XM01.1258.000.00	Stem-N Std 4 Ti-V + CaP	Ti-V + CaP	STD	Ti6Al4V - ISO 5832/3
XM01.1259.000.00	Stem-N Std 5 Ti-V + CaP	Ti-V + CaP	STD	Ti6Al4V - ISO 5832/3
XM01.1260.000.00	Stem-N Std 6 Ti-V + CaP	Ti-V + CaP	STD	Ti6Al4V - ISO 5832/3
XM01.1261.000.00	Stem-N Std 7 Ti-V + CaP	Ti-V + CaP	STD	Ti6Al4V - ISO 5832/3
XM01.1248.000.00	Stem-N Lat 1 Ti-V + CaP	Ti-V + CaP	LAT	Ti6Al4V - ISO 5832/3
XM01.1249.000.00	Stem-N Lat 2 Ti-V + CaP	Ti-V + CaP	LAT	Ti6Al4V - ISO 5832/3
XM01.1250.000.00	Stem-N Lat 3 Ti-V + CaP	Ti-V + CaP	LAT	Ti6Al4V - ISO 5832/3
XM01.1251.000.00	Stem-N Lat 4 Ti-V + CaP	Ti-V + CaP	LAT	Ti6Al4V - ISO 5832/3
XM01.1252.000.00	Stem-N Lat 5 Ti-V + CaP	Ti-V + CaP	LAT	Ti6Al4V - ISO 5832/3
XM01.1253.000.00	Stem-N Lat 6 Ti-V + CaP	Ti-V + CaP	LAT	Ti6Al4V - ISO 5832/3
XM01.1254.000.00	Stem-N Lat 7 Ti-V + CaP	Ti-V + CaP	LAT	Ti6Al4V - ISO 5832/3
XM01.1080.000.00	Stem-N Lat 1 HA BACT	HA + BACT	LAT	Ti6Al4V - ISO 5832/3
XM01.1081.000.00	Stem-N Lat 2 HA BACT	HA + BACT	LAT	Ti6Al4V - ISO 5832/3
XM01.1082.000.00	Stem-N Lat 3 HA BACT	HA + BACT	LAT	Ti6Al4V - ISO 5832/3
XM01.1083.000.00	Stem-N Lat 4 HA BACT	HA + BACT	LAT	Ti6Al4V - ISO 5832/3
XM01.1084.000.00	Stem-N Lat 5 HA BACT	HA + BACT	LAT	Ti6Al4V - ISO 5832/3
XM01.1085.000.00	Stem-N Lat 6 HA BACT	HA + BACT	LAT	Ti6Al4V - ISO 5832/3
XM01.1086.000.00	Stem-N Lat 7 HA BACT	HA + BACT	LAT	Ti6Al4V - ISO 5832/3
XM01.1087.000.00	Stem-N Std 1 HA BACT	HA + BACT	STD	Ti6Al4V - ISO 5832/3
XM01.1088.000.00	Stem-N Std 2 HA BACT	HA + BACT	STD	Ti6Al4V - ISO 5832/3
XM01.1089.000.00	Stem-N Std 3 HA BACT	HA + BACT	STD	Ti6Al4V - ISO 5832/3
XM01.1090.000.00	Stem-N Std 4 HA BACT	HA + BACT	STD	Ti6Al4V - ISO 5832/3
XM01.1091.000.00	Stem-N Std 5 HA BACT	HA + BACT	STD	Ti6Al4V - ISO 5832/3
XM01.1092.000.00	Stem-N Std 6 HA BACT	HA + BACT	STD	Ti6Al4V - ISO 5832/3
XM01.1093.000.00	Stem-N Std 7 HA BACT	HA + BACT	STD	Ti6Al4V - ISO 5832/3
XM01.1094.000.00	Stem-N Lat 1 CaP BACT	CaP + BACT	LAT	Ti6Al4V - ISO 5832/3
XM01.1095.000.00	Stem-N Lat 2 CaP BACT	CaP + BACT	LAT	Ti6Al4V - ISO 5832/3
XM01.1096.000.00	Stem-N Lat 3 CaP BACT	CaP + BACT	LAT	Ti6Al4V - ISO 5832/3
XM01.1097.000.00	Stem-N Lat 4 CaP BACT	CaP + BACT	LAT	Ti6Al4V - ISO 5832/3
XM01.1098.000.00	Stem-N Lat 5 CaP BACT	CaP + BACT	LAT	Ti6Al4V - ISO 5832/3
XM01.1099.000.00	Stem-N Lat 6 CaP BACT	CaP + BACT	LAT	Ti6Al4V - ISO 5832/3
XM01.1100.000.00	Stem-N Lat 7 CaP BACT	CaP + BACT	LAT	Ti6Al4V - ISO 5832/3
XM01.1101.000.00	Stem-N Std 1 CaP BACT	CaP + BACT	STD	Ti6Al4V - ISO 5832/3
XM01.1102.000.00	Stem-N Std 2 CaP BACT	CaP + BACT	STD	Ti6Al4V - ISO 5832/3
XM01.1103.000.00	Stem-N Std 3 CaP BACT	CaP + BACT	STD	Ti6Al4V - ISO 5832/3
XM01.1104.000.00	Stem-N Std 4 CaP BACT	CaP + BACT	STD	Ti6Al4V - ISO 5832/3
XM01.1105.000.00	Stem-N Std 5 CaP BACT	CaP + BACT	STD	Ti6Al4V - ISO 5832/3
XM01.1106.000.00	Stem-N Std 6 CaP BACT	CaP + BACT	STD	Ti6Al4V - ISO 5832/3
XM01.1107.000.00	Stem-N Std 7 CaP BACT	CaP + BACT	STD	Ti6Al4V - ISO 5832/3
XM01.1108.000.00	Stem-N Lat 1 Ti-V BACT	Ti-V + BACT	LAT	Ti6Al4V - ISO 5832/3
XM01.1109.000.00	Stem-N Lat 2 Ti-V BACT	Ti-V + BACT	LAT	Ti6Al4V - ISO 5832/3
XM01.1110.000.00	Stem-N Lat 3 Ti-V BACT	Ti-V + BACT	LAT	Ti6Al4V - ISO 5832/3
XM01.1111.000.00	Stem-N Lat 4 Ti-V BACT	Ti-V + BACT	LAT	Ti6Al4V - ISO 5832/3
XM01.1112.000.00	Stem-N Lat 5 Ti-V BACT	Ti-V + BACT	LAT	Ti6Al4V - ISO 5832/3
XM01.1113.000.00	Stem-N Lat 6 Ti-V BACT	Ti-V + BACT	LAT	Ti6Al4V - ISO 5832/3
XM01.1114.000.00	Stem-N Lat 7 Ti-V BACT	Ti-V + BACT	LAT	Ti6Al4V - ISO 5832/3
XM01.1115.000.00	Stem-N Std 1 Ti-V BACT	Ti-V + BACT	STD	Ti6Al4V - ISO 5832/3
XM01.1116.000.00	Stem-N Std 2 Ti-V BACT	Ti-V + BACT	STD	Ti6Al4V - ISO 5832/3
XM01.1117.000.00	Stem-N Std 3 Ti-V BACT	Ti-V + BACT	STD	Ti6Al4V - ISO 5832/3

Stem-N Neck Preserving Primary Hip Reconstruction

Implants Item Codes



Item Code	Description	Coating	Type	Main Material
XM01.1227.000.00 *	Stem-N Std 1 Ti-V	Ti-V	STD	Ti6Al4V - ISO 5832/3
XM01.1228.000.00 *	Stem-N Std 2 Ti-V	Ti-V	STD	Ti6Al4V - ISO 5832/3
XM01.1229.000.00 *	Stem-N Std 3 Ti-V	Ti-V	STD	Ti6Al4V - ISO 5832/3
XM01.1230.000.00 *	Stem-N Std 4 Ti-V	Ti-V	STD	Ti6Al4V - ISO 5832/3
XM01.1231.000.00 *	Stem-N Std 5 Ti-V	Ti-V	STD	Ti6Al4V - ISO 5832/3
XM01.1232.000.00 *	Stem-N Std 6 Ti-V	Ti-V	STD	Ti6Al4V - ISO 5832/3
XM01.1233.000.00 *	Stem-N Std 7 Ti-V	Ti-V	STD	Ti6Al4V - ISO 5832/3
XM01.1234.000.00 *	Stem-N Lat 1 Ti-V + HA	Ti-V + HA	LAT	Ti6Al4V - ISO 5832/3
XM01.1235.000.00 *	Stem-N Lat 2 Ti-V + HA	Ti-V + HA	LAT	Ti6Al4V - ISO 5832/3
XM01.1236.000.00 *	Stem-N Lat 3 Ti-V + HA	Ti-V + HA	LAT	Ti6Al4V - ISO 5832/3
XM01.1237.000.00 *	Stem-N Lat 4 Ti-V + HA	Ti-V + HA	LAT	Ti6Al4V - ISO 5832/3
XM01.1238.000.00 *	Stem-N Lat 5 Ti-V + HA	Ti-V + HA	LAT	Ti6Al4V - ISO 5832/3
XM01.1239.000.00 *	Stem-N Lat 6 Ti-V + HA	Ti-V + HA	LAT	Ti6Al4V - ISO 5832/3
XM01.1240.000.00 *	Stem-N Lat 7 Ti-V + HA	Ti-V + HA	LAT	Ti6Al4V - ISO 5832/3
XM01.1241.000.00 *	Stem-N Std 1 Ti-V + HA	Ti-V + HA	STD	Ti6Al4V - ISO 5832/3
XM01.1242.000.00 *	Stem-N Std 2 Ti-V + HA	Ti-V + HA	STD	Ti6Al4V - ISO 5832/3
XM01.1243.000.00 *	Stem-N Std 3 Ti-V + HA	Ti-V + HA	STD	Ti6Al4V - ISO 5832/3
XM01.1244.000.00 *	Stem-N Std 4 Ti-V + HA	Ti-V + HA	STD	Ti6Al4V - ISO 5832/3
XM01.1245.000.00 *	Stem-N Std 5 Ti-V + HA	Ti-V + HA	STD	Ti6Al4V - ISO 5832/3
XM01.1246.000.00 *	Stem-N Std 6 Ti-V + HA	Ti-V + HA	STD	Ti6Al4V - ISO 5832/3
XM01.1247.000.00 *	Stem-N Std 7 Ti-V + HA	Ti-V + HA	STD	Ti6Al4V - ISO 5832/3
XM01.1262.000.00 *	Stem-N Lat 1 Ti-A	Ti-A	LAT	Ti6Al4V - ISO 5832/3
XM01.1263.000.00 *	Stem-N Lat 2 Ti-A	Ti-A	LAT	Ti6Al4V - ISO 5832/3
XM01.1264.000.00 *	Stem-N Lat 3 Ti-A	Ti-A	LAT	Ti6Al4V - ISO 5832/3
XM01.1265.000.00 *	Stem-N Lat 4 Ti-A	Ti-A	LAT	Ti6Al4V - ISO 5832/3
XM01.1266.000.00 *	Stem-N Lat 5 Ti-A	Ti-A	LAT	Ti6Al4V - ISO 5832/3
XM01.1267.000.00 *	Stem-N Lat 6 Ti-A	Ti-A	LAT	Ti6Al4V - ISO 5832/3
XM01.1268.000.00 *	Stem-N Lat 7 Ti-A	Ti-A	LAT	Ti6Al4V - ISO 5832/3
XM01.1269.000.00 *	Stem-N Std 1 Ti-A	Ti-A	STD	Ti6Al4V - ISO 5832/3
XM01.1270.000.00 *	Stem-N Std 2 Ti-A	Ti-A	STD	Ti6Al4V - ISO 5832/3
XM01.1271.000.00 *	Stem-N Std 3 Ti-A	Ti-A	STD	Ti6Al4V - ISO 5832/3
XM01.1272.000.00 *	Stem-N Std 4 Ti-A	Ti-A	STD	Ti6Al4V - ISO 5832/3
XM01.1273.000.00 *	Stem-N Std 5 Ti-A	Ti-A	STD	Ti6Al4V - ISO 5832/3
XM01.1274.000.00 *	Stem-N Std 6 Ti-A	Ti-A	STD	Ti6Al4V - ISO 5832/3
XM01.1275.000.00 *	Stem-N Std 7 Ti-A	Ti-A	STD	Ti6Al4V - ISO 5832/3
XM01.1276.000.00 *	Stem-N Lat 1 Ti-A + HA	Ti-A + HA	LAT	Ti6Al4V - ISO 5832/3
XM01.1277.000.00 *	Stem-N Lat 2 Ti-A + HA	Ti-A + HA	LAT	Ti6Al4V - ISO 5832/3
XM01.1278.000.00 *	Stem-N Lat 3 Ti-A + HA	Ti-A + HA	LAT	Ti6Al4V - ISO 5832/3
XM01.1279.000.00 *	Stem-N Lat 4 Ti-A + HA	Ti-A + HA	LAT	Ti6Al4V - ISO 5832/3
XM01.1280.000.00 *	Stem-N Lat 5 Ti-A + HA	Ti-A + HA	LAT	Ti6Al4V - ISO 5832/3
XM01.1281.000.00 *	Stem-N Lat 6 Ti-A + HA	Ti-A + HA	LAT	Ti6Al4V - ISO 5832/3
XM01.1282.000.00 *	Stem-N Lat 7 Ti-A + HA	Ti-A + HA	LAT	Ti6Al4V - ISO 5832/3
XM01.1283.000.00 *	Stem-N Std 1 Ti-A + HA	Ti-A + HA	STD	Ti6Al4V - ISO 5832/3
XM01.1284.000.00 *	Stem-N Std 2 Ti-A + HA	Ti-A + HA	STD	Ti6Al4V - ISO 5832/3
XM01.1285.000.00 *	Stem-N Std 3 Ti-A + HA	Ti-A + HA	STD	Ti6Al4V - ISO 5832/3
XM01.1286.000.00 *	Stem-N Std 4 Ti-A + HA	Ti-A + HA	STD	Ti6Al4V - ISO 5832/3
XM01.1287.000.00 *	Stem-N Std 5 Ti-A + HA	Ti-A + HA	STD	Ti6Al4V - ISO 5832/3
XM01.1288.000.00 *	Stem-N Std 6 Ti-A + HA	Ti-A + HA	STD	Ti6Al4V - ISO 5832/3
XM01.1289.000.00 *	Stem-N Std 7 Ti-A + HA	Ti-A + HA	STD	Ti6Al4V - ISO 5832/3
XM01.1290.000.00 *	Stem-N Lat 1 Ti-A + CaP	Ti-A + CaP	LAT	Ti6Al4V - ISO 5832/3
XM01.1291.000.00 *	Stem-N Lat 2 Ti-A + CaP	Ti-A + CaP	LAT	Ti6Al4V - ISO 5832/3
XM01.1292.000.00 *	Stem-N Lat 3 Ti-A + CaP	Ti-A + CaP	LAT	Ti6Al4V - ISO 5832/3

Stem-N Neck Preserving Primary Hip Reconstruction

Implants Item Codes



Item Code	Description	Coating	Type	Main Material
XM01.1293.000.00 *	Stem-N Lat 4 Ti-A + CaP	Ti-A + CaP	LAT	Ti6Al4V - ISO 5832/3
XM01.1294.000.00 *	Stem-N Lat 5 Ti-A + CaP	Ti-A + CaP	LAT	Ti6Al4V - ISO 5832/3
XM01.1295.000.00 *	Stem-N Lat 6 Ti-A + CaP	Ti-A + CaP	LAT	Ti6Al4V - ISO 5832/3
XM01.1296.000.00 *	Stem-N Lat 7 Ti-A + CaP	Ti-A + CaP	LAT	Ti6Al4V - ISO 5832/3
XM01.1297.000.00 *	Stem-N Std 1 Ti-A + CaP	Ti-A + CaP	STD	Ti6Al4V - ISO 5832/3
XM01.1298.000.00 *	Stem-N Std 2 Ti-A + CaP	Ti-A + CaP	STD	Ti6Al4V - ISO 5832/3
XM01.1299.000.00 *	Stem-N Std 3 Ti-A + CaP	Ti-A + CaP	STD	Ti6Al4V - ISO 5832/3
XM01.1300.000.00 *	Stem-N Std 4 Ti-A + CaP	Ti-A + CaP	STD	Ti6Al4V - ISO 5832/3
XM01.1301.000.00 *	Stem-N Std 5 Ti-A + CaP	Ti-A + CaP	STD	Ti6Al4V - ISO 5832/3
XM01.1302.000.00 *	Stem-N Std 6 Ti-A + CaP	Ti-A + CaP	STD	Ti6Al4V - ISO 5832/3
XM01.1303.000.00 *	Stem-N Std 7 Ti-A + CaP	Ti-A + CaP	STD	Ti6Al4V - ISO 5832/3

* Special request items

■ Stem-N Instrument Set | B076.4001.000.00

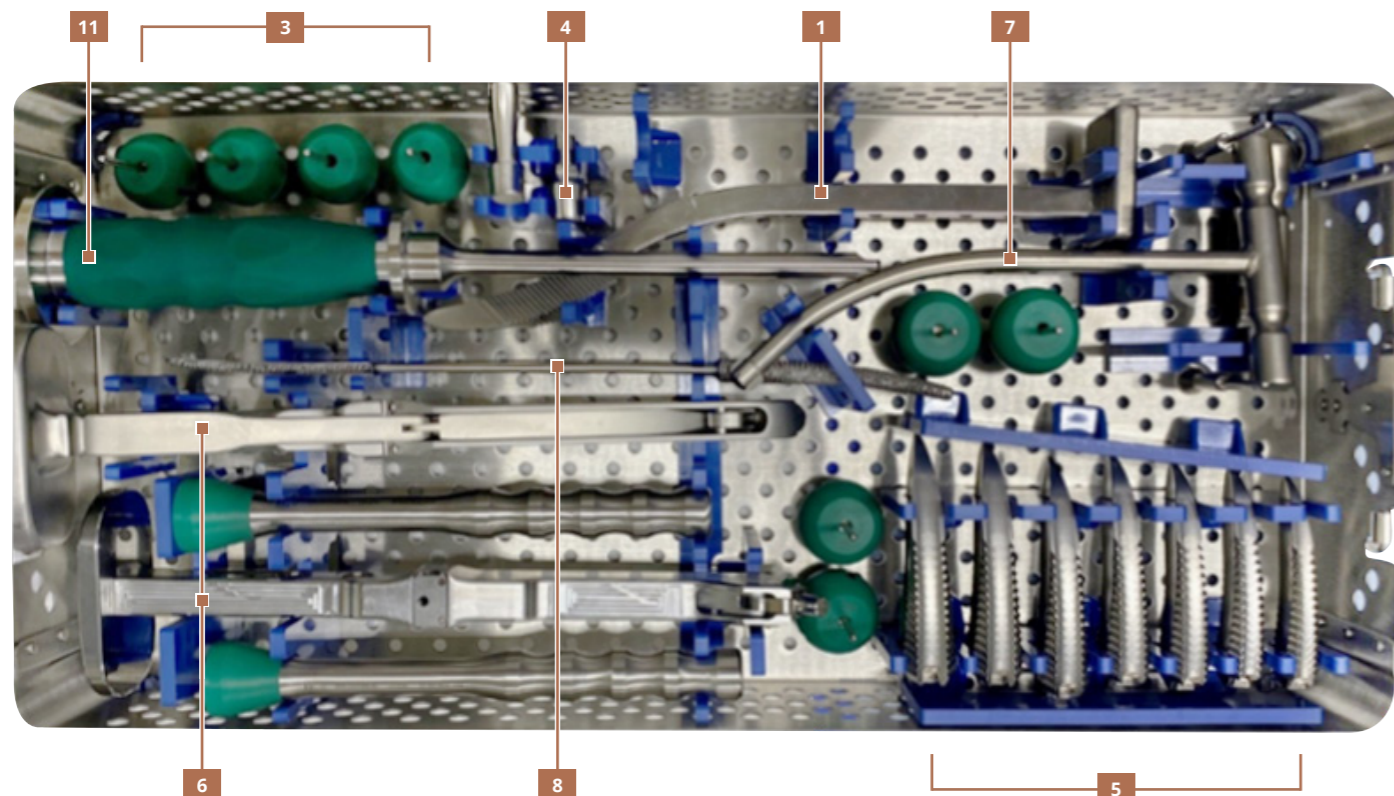

■ Set Content

N°	Item Code	Description	Qty per SET
	B076.4001.001.00	TRAY STEM N	1
1	XM01.5089.000.00	Femoral Canal Opener	1
2	XM01.5093.000.00	Stem Positioner	1
3	XM01.5104.000.00	Trial Ball Head 32S	1
	XM01.5105.000.00	Trial Ball Head 32M	1
	XM01.5106.000.00	Trial Ball Head 32L	1
	XM01.5107.000.00	Trial Ball Head 32XL	1
	XM01.5108.000.00	Trial Ball Head 36S	1
	XM01.5109.000.00	Trial Ball Head 36M	1
	XM01.5110.000.00	Trial Ball Head 36L	1
	XM01.5111.000.00	Trial Ball Head 36XL	1
4	XM01.5137.000.00	Trial Neck Std	1
	XM01.5138.000.00	Trial Neck Lat	1
5	XM01.5139.000.00	Broach 1	1
	XM01.5140.000.00	Broach 2	1
	XM01.5141.000.00	Broach 3	1
	XM01.5142.000.00	Broach 4	1
	XM01.5143.000.00	Broach 5	1
	XM01.5144.000.00	Broach 6	1
	XM01.5145.000.00	Broach 7	1
11	XM01.5206.000.00	Stem Impactor	1
6	XM01.5212.000.00	Broach Handle Male	2
7	XM01.5213.000.00	Canal Opener Small	1
8	XM01.5215.000.00	Curved Canal Opening Rasp	1
9	XM01.5216.000.00 *	Stem Extractor	1
10	XM01.5098.000.00 *	Trial Ball Head 22S	1
	XM01.5099.000.00 *	Trial Ball Head 22M	1
	XM01.5100.000.00 *	Trial Ball Head 28S	1
	XM01.5101.000.00 *	Trial Ball Head 28M	1
	XM01.5102.000.00 *	Trial Ball Head 28L	1
	XM01.5103.000.00 *	Trial Ball Head 28XL	1
	XM01.5112.000.00 *	Trial Ball Head 40S	1
	XM01.5113.000.00 *	Trial Ball Head 40M	1
	XM01.5114.000.00 *	Trial Ball Head 40L	1
	XM01.5115.000.00 *	Trial Ball Head 40XL	1
	XM01.5211.000.00 *	Trial Ball Head 28XXL	1

* Special request items

MIS Double Offset Broach Handles

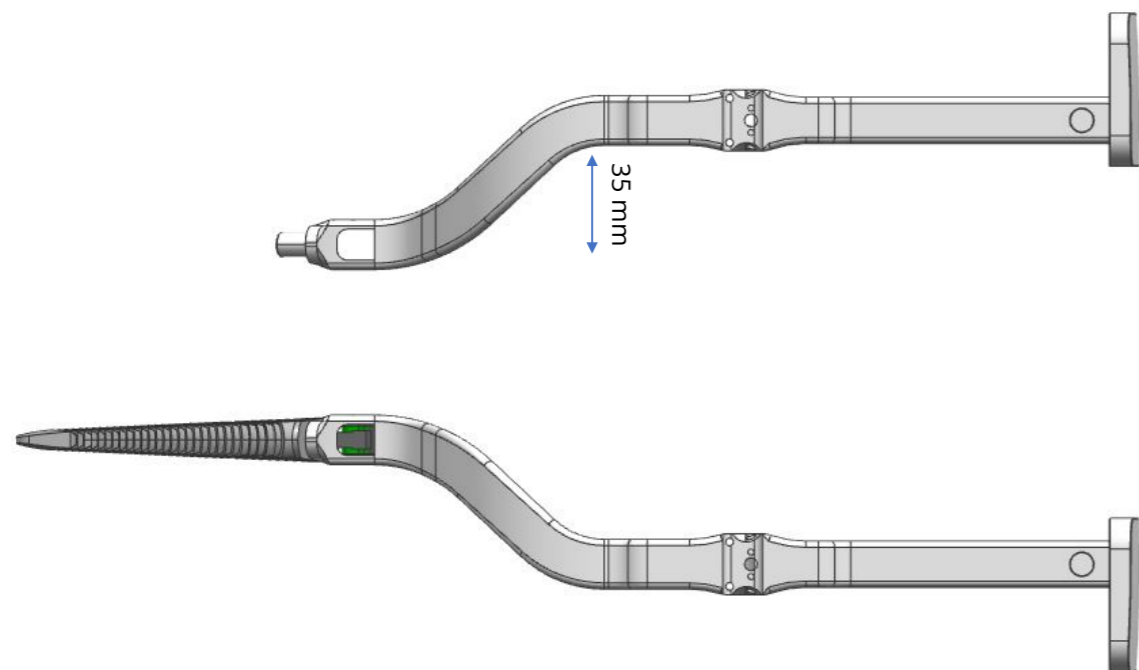

Set Content

Item Code	Description	Qty per SET
BO76.5516.000.00	Double Offset Handle - Right	1
BO76.5517.000.00	Double Offset Handle - Left	1
BO76.5518.000.00	Osteotome	1
BO76.5519.000.00	Stem Impactor Module	1
BO76.5514.000.00	Spoon Lever	1
BO76.5515.000.00	Teethed Curved Broach	1

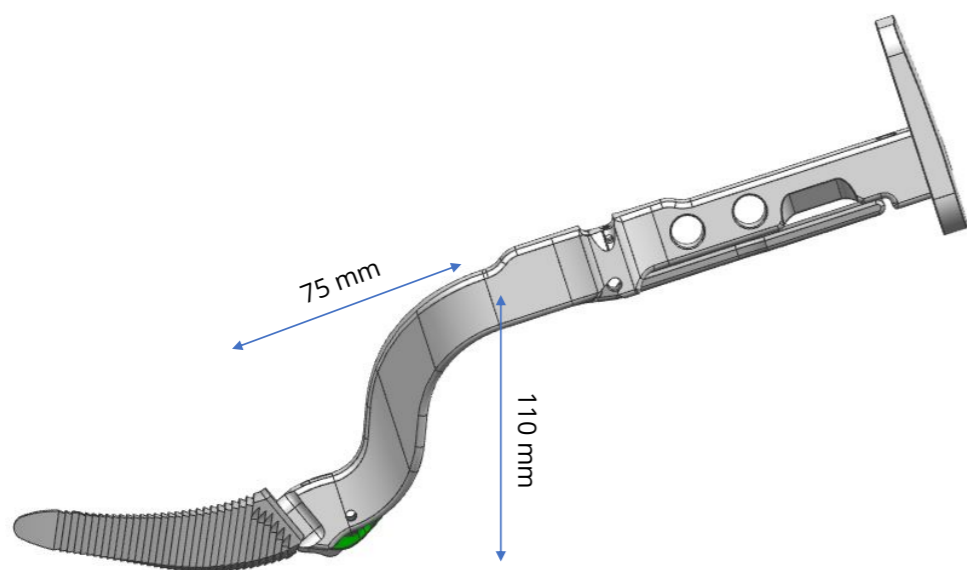

Double Offset Broach Handles (common components with Traction-Bed): Components

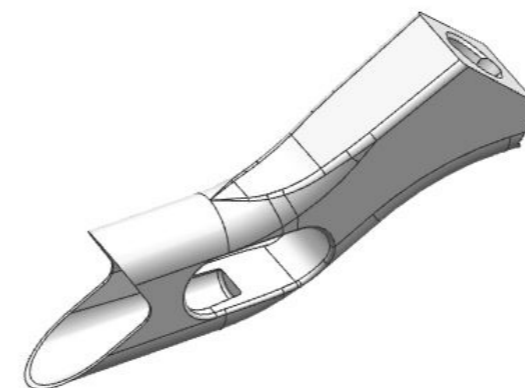

Osteotome for MIS

Item Code	Description
BO76.5518.000.00	Osteotome - M/N



Direction Handle

Item Code	Description
BO76.5532.000.00	Alignment Rod

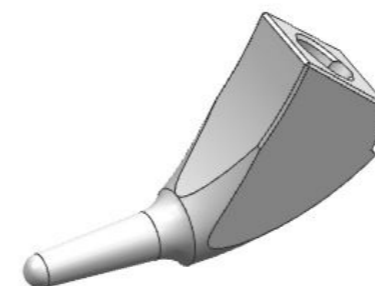

Stem Impactor for MIS

Item Code	Description
BO76.5519.000.00	Stem Impactor Module M/N

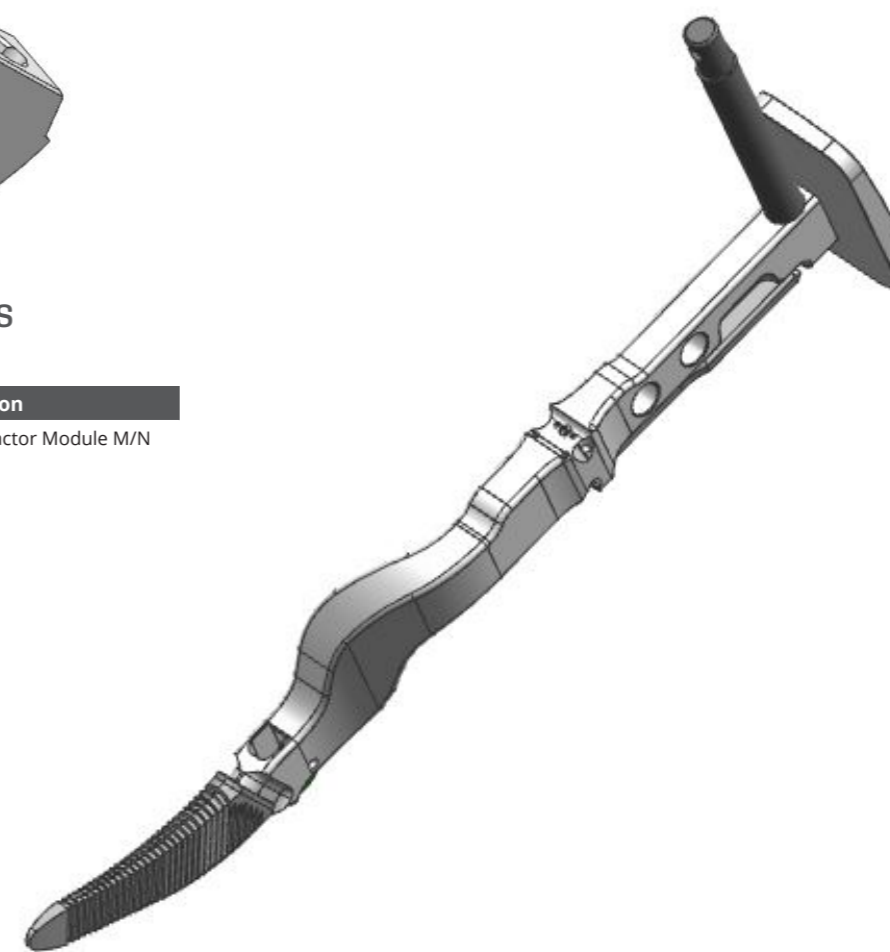

Contact Details

Lincotek Bologna S.r.l.

Via Buoizzi 13/15

40057 Cadriano di Granarolo Emilia (BO) · Italy

 www.recon-i.com

 info@recon-i.com

 **B-MED S.r.l.**
Via Bazzanese 32/7
40033 Casalecchio di Reno (BO) · Italy

 **Lincotek Bologna S.r.l.**
Via Buoizzi 13/15
40057 Cadriano (BO) · Italy